

Bridgend County Borough Council Parking Standards 2011 Consultation Draft



Volume 1 - Guidance and Standards

Based upon the CSS Wales Parking Standards 2008 (as endorsed by Sewta)

***Bridgend Parking Standards 2011
Consultation Draft***

CONTENT	PAGE
1. PREAMBLE	6
2. PURPOSE	6
3. APPLICATION	6
4. STRATEGIC FRAMEWORK	6
5. PARKING ZONES	9
6. APPLICATION OF PARKING STANDARDS	10
7. DEFINITIONS AND NOTES	12
8. GENERAL STATEMENT	14
9. PARKING STANDARDS BY LAND USE	15
(a) Residential	16
(b) Offices	19
(c) Shops	21
(d) Retail Warehousing & Garages	23
(e) Industry & Industrial Warehousing	24
(f) Places of Entertainment	27
(g) Hotels & Restaurants	29
(h) Community Establishments	31
(i) Educational Establishments	33
APPENDICES	37
1. DISABLED PARKING	39
2. LAYOUT OF PARKING AREAS	41
3. CYCLE PARKING STANDARDS	43
4. MOTORCYCLE PARKING STANDARDS	45
5. SUSTAINABILITY	46
6. LANDSCAPING	48
BIBLIOGRAPHY	49

CSS WALES

BRIDGEND PARKING STANDARDS

Design and Good Practice

Consultation draft

2011

1 PREAMBLE

These Parking Standards should be read in conjunction with the Regional Transport Plan, the Unitary Development Plan, or its replacement the Local Development Plan, and Supplementary Planning Guidance. Parking requirements are listed according to land use and location and they list requirements for commercial vehicles, cars, motor cycles and cycles. The use of travel plans and the sustainability of new development are also addressed. The Parking Standards will be material to decisions on individual planning applications and will be used as a technical reference document.

2 PURPOSE

These Parking Standards seek to ensure a transparent and consistent approach to the provision of parking, submission of travel plans and sustainability considerations that will inform developers, designers and builders of what is expected of them and from them at an early stage of the development process.

3 APPLICATION

These Parking Standards will inform observations made by the Highway Authority on applications received for Planning Permission.

4 STRATEGIC FRAMEWORK

4.1 This document provides detailed parking requirements according to land use and type of development. It has been prepared by officers of Bridgend County Borough Council and is largely based upon an initial guidance document prepared by CSS Wales on behalf of all 22 unitary Authorities in Wales that constitute the four regional transport consortia: Sewta; SWWITCH; Taith; and TraCC, taking account of local factors and sustainability issues. Its aims are:

- (a) to assist developers, designers and builders in the preparation and submission of planning applications;
- (b) to achieve a common approach to the provision of vehicle parking facilities associated with new development and change of use.

4.2 The underlying rationale for the South Wales Parking Guidelines Revised Edition of 1993 prepared by the Standing Conference on Regional Policy was to provide sufficient parking to avoid the need for vehicles to park on-street and thereby cause congestion, danger and visual intrusion.

4.3 Since 1993, fundamental changes in national planning framework and transport policy have taken place with the publication of PPG 13 (in England) in 1994, the Environment Act 1995, the Road Traffic Reduction Acts 1997 and 1998, A New Deal for Transport: Better for Everyone and Transporting Wales into the Future (1998), Planning Policy Wales in 2010, Planning Policy Wales Technical Advice Note 18 (TAN 18) in 2007 and Manual for Streets in 2007. In particular, paragraph 8.4.2 of Planning Policy Wales 2010 states that *“Car Parking Provision is a major influence on the choice of means of transport and the pattern of development. Local authorities should ensure that new developments provide lower levels of parking than have generally been achieved in the past. Minimum parking standards are no longer appropriate. Local authorities should develop an integrated strategy on parking to support the overall transport and locational policies of the development plan.”* TAN 18 supplements Planning Policy Wales and states that *‘Maximum car parking standards should be used at regional and local level as a form of demand management’* and, that for new development, regard should be given to alternative transport modes, economic objectives, public and shared parking arrangements.

4.4 Planning Policy Wales 2010 seeks to apply maximum standards to all new developments with the aim of reducing reliance on use of the private motor car. There is no evidence to suggest that car ownership levels have reduced but rather, they are forecast to grow by 25% between 2001 and 2036. Consequently, it is now necessary to consider parking levels within residential developments, at the residential trip end and point of origin of many journeys (a residential dwelling), differently from the point of destination (e.g. commercial, leisure, retail, educational development etc). To date central government has not indicated a desire to reduce car ownership levels but has expressed a clear aim to reduce unnecessary private car journeys in an effort to reduce carbon emissions and improve public health. These new local standards seek to address these issues by providing realistic levels of parking

within residential developments and maximum levels of parking at other locations. The targets and actions necessary to support the maximum levels of provision at other than residential developments must be supported by Travel Plans and sustainability Assessments which take account of the proximity of public transport and local community facilities to any new development. This acknowledges the fact that limiting parking availability at the residential trip end does not necessarily discourage car ownership. In practice it can push vehicle parking onto the public highway and, rather than acting as an informal speed reducing feature, can diminish the streetscape and obstruct the passage of emergency service vehicles and public transport to the detriment of highway safety.

- 4.5 A fundamental departure from previous practice is the requirement by Planning Policy Wales and TAN 18, reflected in the CSS Wales document for local authorities to introduce a system of zones for parking purposes into their Local Development Plans. This is dealt with in Volume 2 which lays out six such zones, each with differing designated levels of parking requirement for development control purposes. It is the responsibility of individual Local Authorities to decide which of these zones are applicable and where the zone boundaries should be drawn within their area.
- 4.6 This new approach to transport, with the change from predicting and providing for cars to managing traffic and reducing car dependency, means a new role for parking provision and control which this revision has been prepared to address. The aim as previously remains to ensure that new development or a change of use is accompanied by sufficient parking space for private cars and service vehicles to avoid the need for vehicles to park on street and thereby cause congestion, danger and visual intrusion. Since the introduction of the Department of Transport publication, Manual for Streets 2007, it has been recognised that, in residential situations, both unallocated on- street parking and off street parking, can play a part in the overall parking provision for new developments. This will generally require roads in new estates to be widened, locally or throughout their length, so that parked vehicles do not intrude into running lanes or prevent the free passage of vehicles. This provides potential for neighbouring or mixed use developments sharing parking spaces, for example at different times of the day and week maximising the effective use of developable land and increasing housing densities in accordance with central government aspirations.
- 4.7 This guide is intended to cover all built up and rural areas in order to facilitate the application of appropriate and sufficient levels of parking in all circumstances.
- 4.8 General guidance on all aspects of parking, including on and off street parking and the needs of the disabled is available in the publication Parking Strategies and Management, IHT (2005). Beware that some of the content of that publication refers specifically to PPG13, which does not apply to Wales. The Department for Communities and Local Government research document, Residential Car Parking Research, provides more detailed guidance, although it is based on average car ownership levels in England only and excludes any consideration of demographics. The design of parking areas should also take account of the guidance contained within the assessment guidelines of the Park Mark safer parking initiative of the Association of Chief Police Officers as well as the more general requirements of Planning Policy Wales Technical Advice Note 12: Design (TAN12).
- 4.9 In compiling these standards the following policies are considered to be particularly relevant:

4.9.1 Planning Policy Wales 2010

Paragraph 8.4.2 states:

Car parking provision is a major influence on the choice of means of transport and the pattern of development. Local Authorities should ensure that new developments provide lower levels of parking than have generally been achieved in the past. Minimum parking standards are no longer appropriate. Local authorities should develop an integrated strategy on parking to support the overall transport and locational policies of the UDP.

Paragraph 8.4.3 states:

Local Authorities should consider parking issues on a joint basis with neighbouring authorities, utilising existing collaborative bodies such as regional planning fora or transport consortia. They should jointly establish maximum levels of parking for broad classes of development together with a threshold size of development above which such levels will apply.

4.9.2 TAN 18 Transport

Paragraph 4.7 states:

“In determining maximum car parking standards for new development, regard should be given to:

- *public transport accessibility and opportunities or proposals for enhancement;*
- *targets and opportunities for walking and cycling;*
- *objectives for economic development including tourism;*
- *the availability in the general area of safe public on- and off-street parking provision; and*
- *potential for neighbouring or mixed use developments sharing parking spaces, for example at different times of the day or week”.*

Paragraph 4.16 states:

“Local Planning Authorities should give greater weight (than if considering non-residential uses) to the potential adverse impacts likely to result from on street parking when the design and layout of the street is unlikely to satisfactorily cope with additional residential parking pressures”.

4.9.3 Manual for Streets

Paragraph 8.3.37 states:

“A key objective of PPS 3 is to ensure that land is used efficiently, and to this end the total space taken up by parking needs to be minimised (Wales: refer to TAN 18). The more flexible the use of parking spaces, the more efficient the use of space”.

4.9.4 Sewta Regional Transport Plan

The immediate and direct impact of car parking is local and therefore criteria or standards that determine the level of provision have to take account of local factors which may be addressed within the sustainability index at Appendix 5. Sewta acknowledges the influence that parking provision has on the location of development and in order to provide a uniform or common standard for assessing parking needs in the region, the Regional Transport Plan has introduced policy CPP1 which *“supports a consistent approach to car parking standards across the region.”*

4.9.5 Unitary Development Plan

This Supplementary Planning Guidance is supported by policies T8 and T9 in the Unitary Development Plan which deal directly with non-operational parking in established commercial centres. However, the defined zones in this SPG are based on accessibility rather than solely land-use characteristics. It is considered that these provide further clarity in sustainability terms and assist in the determination of locations where specific parking values would apply.

5 PARKING ZONES (as identified in CSS Wales – Wales Parking Standards, 2008)

Zone 1 – City Core.

This is limited to the centre of the largest towns such as Cardiff, Newport and Swansea. This means that there are no Zone 1 locations in Bridgend county borough. Typically there will be a wide range of public transport services, bus and rail. There will be very little car parking within the curtilage of individual buildings and that which there is, is almost entirely operational parking. The area is likely to be the commercial focus of a large hinterland. All on-street parking is regulated; all public off-street car parking is charged for.

Zone 2 – Town Centre or City Centre Fringe.

The centre of towns which local people regard as their destination for most activity which is not met within their own local community, or an area immediately adjacent to the City Core (Zone 1). The area has a full range of retail activity and many commercial businesses, all within walking distance. The area is the focus of the local bus network and is likely to contain a railway station. Built density is high with little private car parking. There are significant parking restrictions and substantial amounts of off-street car parking available to the public.

Zone 3 - Urban.

Very much part of a substantial built up area with a number of basic local facilities within 400m walking distance. A range of bus routes offering up to 6 buses per hour; the range of destinations offering practical access to most but not all essential facilities. The curtilage of the site restricts, to an extent, what car parking can be provided. There are likely to be some restrictions on on-street parking and other available off-street parking is severely limited or non-existent.

Zone 4 – Suburban or Near Urban.

This zone comprises the outer edges of the largest towns; suburban locations in towns; the whole of smaller settlements offering a range of local facilities. There is an at least hourly bus service to the town centre and there may also be a railway station in the town. Local facilities include a local centre within 400m walking distance. Some other basic amenities such as a doctor's surgery are also available within the same walking distance.

Zone 5 – Countryside.

Zone 5 encompasses areas, including small villages, with a few local facilities within walking distance. Motorised travel is required for most journeys, although there is some local employment. Public transport services have less than hourly frequency and then only to one local centre. There is no shortage of land for parking provision within the site but the adjacent highway system offers limited opportunities to park cars.

Zone 6 – Deep Rural.

This zone comprises scattered individual buildings and is characterised by areas with no local facilities within walking distance. Motorised travel is required for all journeys but the most local. Public transport services are very infrequent or beyond walking distance. There is no shortage of land for parking provision within the site but the adjacent highway system offers no opportunities to park cars because of the narrowness of the highway. There are no Zone 6 locations in Bridgend county borough.

Notes relating to parking zones

1. References above to 'public transport' should be taken to mean bus or train services.
2. Bus service frequencies above must operate consistently between 7am and 7pm to qualify.
3. For information on acceptable walking distances refer to the IHT document *Guidelines for Journeys on Foot* and the DETR advice note *Encouraging Walking*.
4. Details of zonal plans can be found in Volume 2.

6 APPLICATION OF PARKING STANDARDS

- 6.1 The CSS Wales Parking Standards document states that the scale of parking provision varies throughout Wales and local priorities will dictate the manner in which the standards are used. The interpretation and application of these standards will rest with Bridgend County Borough Council but flexibility within the standards allows local circumstances to be taken into account. It is expected that the preparation of Regional Transport Plans, Local Development Plans, the designation of Conservation Areas, Housing Action Areas, General Improvement Areas, etc. will all impact on the interpretation of this document as will the consideration of the Sustainability Assessment (at Appendix 5), and the submission of a developer's Travel Plan for any new non-residential development at a point of destination.
- 6.2 In assessing the parking requirements for a particular development, the planning authority will need to take into account a number of factors in relation to the development and its location. These are listed below but it should be noted that some of these factors are outside direct planning control:
- accessibility to and the service provided by the public transport system;
 - the availability of private buses or the extent of car pooling;
 - the relative proportions of full time / part time / local catchment of labour;
 - accessibility by walking and cycling;
 - the existing and possible future congestion in streets adjacent to the development;
 - accessibility to and the availability of public and/or private car parking space in the vicinity.
- 6.3 It should be noted that reductions in parking standards for developments at a non residential point of destination shall not be applied unless an acceptable travel plan has first been submitted for consideration.
- 6.4 Residential developments (points of origin) will not necessarily warrant specific reductions in the level of parking defined in the standards, although some degree of flexibility may be applied depending on the local circumstances of any particular site and the impact of any potential unallocated on street parking in respect of whether it may be an inconvenience as opposed to a highway safety issue.
- 6.5 Whilst there is a general desire to reduce reliance upon the private car, it is anticipated that there will always be a need to accommodate parking provision for cars at residential points of origin. New residential layout design, as advocated in Manual for Streets will create areas of unallocated parking which can supplement those areas of allocated off street provision (i.e. driveways, garages). A parking requirement for a particular property can count both off-street allocated space and unallocated on street space provided there is a realistic chance the latter will be used and its use will not create obstruction/congestion for other road users. The potential for some reduction to residential parking levels by application of the sustainability index should not be ruled out particularly if the property is in close proximity to local community facilities, public car parks, is well served by public transport and there is evidence of low car ownership, such as a tenancy agreement. Great care should be taken, however, to avoid reductions that will potentially create highway safety issues and consideration must be given to local circumstances e.g. road widths, proximity to turning head or bus stop.
- 6.6 It is considered that the maximum standards for residential development will be based upon the number of bedrooms as identified in the zonal Tables in this document. However, on occasions where there are concerns related to levels of parking, the overall number of rooms (not just bedrooms) per dwelling may be taken into consideration.
- 6.7 This Standard covers all built up and rural areas. The full operational standard will normally be expected together with the non-operational standard for employees' vehicles and in certain cases for visitors. Normally developers will be required to provide all the parking space within the curtilage of the site. Non-operational parking in zones 2 and 3 will not be required where development sites are proposed within established commercial centres identified in the LDP or adopted development plan at the time.
- 6.8 Section 106 Agreements may be negotiated with developers and these can include a number of measures to mitigate the potential impact of development and to address concerns.

-
- 6.9 All parking areas other than residential parking areas off low-trafficked, low speed, minor residential roads should be designed to allow vehicles to enter and leave the site in forward gear.
 - 6.10 Safe pedestrian access routes must be provided within all new car parks.
 - 6.11 Travel plans will be required as a condition of planning consent for all types of non residential development proposals of greater than 1000m² gross floor area and for smaller developments that will have significant transport implications or will be sited where a reduction in vehicular traffic would be particularly beneficial. Appropriate relaxation of the tabled parking requirements may be made following acceptance of the details of a submitted travel plan, always provided that measures to enforce compliance with the travel plan are included within a Section 106 Agreement. Suitable enforcement measures will include the provision of targets, a monitoring regime and the appointment of a travel plan co-ordinator. Best Practice Guidance on the content and monitoring of travel plans is available in the Department for Transport documents "Using the Planning Process to Secure Travel Plans", "Making Residential Travel Plans Work" and its associated "Good Practice Guidelines For New Development".
 - 6.12 In certain circumstances, e.g. Conservation Areas, modifications of the standards may be allowed in order to preserve environmental conditions.
 - 6.13 Examples of the assessment of parking requirements using these Parking Standards are given on page 36.

7 DEFINITIONS AND NOTES

- 7.1 **Operational Parking Space** - Sufficient space to allow the maximum number and size of vehicles likely to serve the development at any one time and to manoeuvre with ease and stand for loading and unloading without inconvenience to vehicles and pedestrians on the public highway or to other users of the site.
- Space for staff cars which, by the nature of the business, is required for day to day operation, may also be included.
- 7.2 **Non-Operational Parking Space** - The space occupied by vehicles not necessarily used for the operation of the premises. This is divided into two classes:
- (a) long term (i.e. commuter parking) mainly occupied by vehicles of staff/clients/customers whose attendance at the premises are of long single durations.,
- (b) short term parking space required by staff/clients/customers whose attendances at the premises are of short single durations.
- 7.3 **Residential Parking Space** - The space required for residents and space for cars of people visiting the residents.
- 7.4 **GROSS Floor Area** - The standards that are related to floor areas are GROSS floor area, i.e. including external walls, except where the text stipulates otherwise in respect of public houses, restaurants, cafes and places of worship.
- 7.5 **Extension or Development of Existing Buildings** – For industrial, office, commercial premises and pre-1914 public houses, under 235m² gross floor area, an increase of 20% will be permitted without the need for additional parking. This allowance can only be made once and any parking displaced must be relocated.
- 7.6 **Public Transport Accessibility** – Public transport provision has the potential to reduce use of the car and where appropriate the level of this provision should be enhanced as planning gain through the planning process. Ease of access to public transport is related to required parking levels through the zoning system introduced by this document and through application of the sustainability considerations contained within Appendix 5.
- 7.7 **Employment Density** - The standards have been assessed on density norms (retail 19.5m² per employee; industrial 35 - 45m² employee, office 16.5m² per employee). Variations in density may be treated on their merits.
- 7.8 **Land Use** - for the purpose of applying the parking standards the following table outlines the land uses specified within the Town and Country Planning (Use Classes) Order 1987.

USE CLASSES IN 1987 ORDER	LAND USES IN PARKING GUIDELINES
Class A1 : Shops Class A2 : Financial & Professional Services Class A3: Food & Drink	Shops Supermarkets and Superstores Retail Warehousing (Cash and Carry) Offices (only in cases where premises are provided principally for visiting members of the public). Restaurants Public Houses Cafes Transport Cafes Licensed Clubs
Class B1 : Business Class B2 : General Industrial Class B3 - B7 : Special Industrial Class B8 : Storage or Distribution	Offices (other than in A2 above) / Light Industry Industry Industry Wholesale Warehousing
Class C1 : Hotels & Hostels Class C2 : Residential Institutions Class-C3 : Dwelling houses	Hotels Homes for the Elderly, Children, etc. Nursing Homes Hospitals General Purpose Houses & Flats Sheltered Accommodation
Class D1 : Non-Residential Institutions Class D2 : Assembly and Leisure	Health Centres Surgeries Churches Primary Schools Nursery Schools Secondary Schools Colleges of Higher & Further Education Libraries Assembly Halls, e.g. Community Centres - Unlicensed Clubs Leisure Centres Sports Clubs Assembly Halls e.g.. Bingo Halls

Note Certain uses within this document do not fall within any specific Use Class and therefore must be dealt with separately (see general uses) e.g. open air markets.

The Standards have not been defined in terms of the 1987 Use Classes Order as this would lead to wide ranges of recommended provision, e.g. Class B1 business encompasses some office uses and industry. A standard anticipating this inter-changeability would be very wide and therefore, standards are only given for specific land use concerned e.g. office or industrial use.

In view of the inter-changeability of uses it may be necessary to impose restrictions on development within these wider classes in order to reflect car-parking requirements.

8 GENERAL STATEMENT

The absence of parking standards for a particular land use does not mean that no parking provision will be required.

In addition the local authority reserves the right to treat all planning applications on their merits according to the size, nature, location, density, employment and traffic generation characteristics of the proposed development and its impact on the local and regional highway network.

The acceptance of a submitted travel plan by the local authority will always require the preparation of a Section 106 Agreement to ensure continual compliance with the contents of the travel plan.

9 PARKING STANDARDS BY LAND USE

- a. Residential**
- b. Offices**
- c. Shops**
- d. Retail Warehousing and Garages**
- e. Industry and Industrial Warehousing**
- f. Places of Entertainment**
- g. Hotels and Restaurants**
- h. Community Establishments**
- i. Educational Establishments**

a) RESIDENTIAL : NEW BUILD & CONVERSIONS

ZONE 1

Type of Development	Residents	Visitors
General Purpose Houses and Apartments		
Houses	0.5 to 1 space per unit	Nil
Apartments	0.5 to 1 space per unit	1 space per 5 units
House conversions to bedsits, or self-contained apartments	0.5 to 1 space per unit	Nil
Special Purpose Housing		
Purpose-built student accommodation	1 space per 25 beds for servicing, wardens and drop-off areas.	Nil
Self-contained elderly persons accommodation (not wardened)	1 space per 2 to 4 units	Nil
Self-contained elderly persons accommodation (wardened)	1 space per 4 units 1 space for warden 1 space per 2 ancillary staff	Nil

Notes relating to residential parking standards for all zones

1. Curtilage parking must be provided wherever possible. Where communal parking is provided, it must be conveniently sited and should be in a location that is also overlooked which will thereby enhance its security. No parking court may accommodate more than 12 parking spaces and depending on local context, designated parking secured by a lockable bollard or other means may be required. Safe pedestrian access must be provided between each dwelling unit and its parking space.
2. Garages should be provided as the most secure parking option wherever possible, preferably located alongside the dwelling. Remote garage blocks must be avoided.
3. Garages may only be counted as parking spaces if they have clear internal dimensions, as suggested by Manual for Streets, for a single garage of 6m x 3m. However, these dimensions must be increased to 6m x 3.8m if disabled person's access is specifically required. All properties with a garage must also have a 6m long driveway which has a width of not less than 3.6m.
4. Visitor parking must be designed as an integral part of any development where it is required and must take into account the needs of disabled persons.
5. For developments *where clear evidence has been supplied that car ownership levels will be lower than average*, a more flexible approach to numbers of parking spaces may be taken. Acceptable evidence of this would be a contractual arrangement with tenants to secure low car ownership levels.

RESIDENTIAL : NEW BUILD & CONVERSIONS

ZONES 2 - 6

Type of Development	Residents	Visitors
General Purpose Houses and Apartments		
Houses	1 space per bedroom (maximum requirement 3 spaces)	1 space per 5 units
Apartments	1 space per bedroom (maximum requirement 3 spaces)	1 space per 5 units
House conversions to bedsits, or self-contained apartments	1 space per bedroom (maximum requirement 3 spaces)	1 space per 5 units
House conversions to residential hostel	1 space per resident staff 1 space per 3 non-resident staff	Nil
Special Purpose Housing		
Self-contained elderly persons dwellings (not wardened)	1 space per 2 - 4 units	1 space per 4 units
Self-contained elderly persons dwellings (wardened)	1 space per 4 units 1 space for warden 1 space per 2 ancillary staff	1 space per 4 units
Purpose built student accommodation under College/University control	1 space per 25 beds for servicing, wardens and drop-off areas	1 space per 10 beds (for students &/or visitors)
Residential childrens homes Homes for elderly persons Nursing homes	1 space per resident staff 1 space per 3 non-resident staff	1 space per 4 beds

Notes relating to residential parking standards for all zones (contd.)

6. In respect of residential homes for the elderly and nursing homes, sufficient operational space must be provided close to the building to enable ambulance access and egress in a forward gear.
7. Low parking standards required for purpose built student accommodation will be based upon a condition requiring a legal tenancy agreement to prevent students parking on neighbouring streets within a 3 mile radius of the accommodation building, public transport facilities, and the provision of a travel plan.
8. As stated throughout these standards are based upon maximum criteria. However, if a development of a single dwelling with reduced parking is proposed then the following additional criteria as broadly outlined in Residential Car Parking Research (Dept of Communities and Local Govt) may be utilised. For example:

-
- 2 bedroom dwelling (generally 5 room unit) - 1 allocated space plus 1 kerbside or other communal unallocated space;
 - 3 bedroom dwelling (generally 6 room unit) - 2 allocated spaces plus 1 kerbside or other communal unallocated space at a rate of 1 space per 3 units;
 - 4 bedroom dwelling (generally 7 room unit) - 2 allocated spaces plus 1 kerbside or other communal unallocated space at a rate of 1 space per 2 units.
9. 'Rooms ' are defined as follows; The count of a household's accommodation does not include bathrooms, toilets, halls or landings, or rooms that can only be used for storage. All other rooms e.g. kitchens, living rooms, bedrooms, utility rooms and studies are counted.
10. It should be noted that any decision to reduce the parking standards from those quoted in the main table will be at the discretion of the local authority and will be based upon the availability of any appropriate kerbside or other unallocated parking areas that are deemed fit for purpose without adversely affecting the safety and effectiveness of the adjacent highway.

b) OFFICES**Use Class B1 Business, Class A2 Financial
& Professional Services (Including Call Centres)****ZONE 1**

Development	Requirement	Development	Requirement
Offices (< 1000m ²)	Nil	Offices (> 1000m ²)	Nil
Call Centres (< 1000m ²)	Nil	Call Centres (> 1000m ²)	Nil

ZONES 2 & 3

Development	Requirement	Development	Requirement
Offices (< 1000m ²)	1 space per 35m ²	Offices (> 1000m ²)	1 space per 60m ²
Call Centres (< 1000m ²)	1 space per 25m ²	Call Centres (> 1000m ²)	1 space per 40m ²

ZONES 4 to 6

Development	Requirement	Development	Requirement
Offices (< 1000m ²)	1 space per 25m ²	Offices (> 1000m ²)	1 space per 40m ²
Call Centres (< 1000m ²)	1 space per 20m ²	Call Centres (> 1000m ²)	1 space per 25m ²

Notes relating to offices parking standards for all zones

1. Office redevelopments, extensions and conversions will have the same requirements as for new build, subject only to note 2 below.
2. For premises up to a maximum of 200m² gross floor area an increase of 20% will be permitted without the need for additional parking. This allowance can only be made once and any parking displaced must be relocated.
3. Consideration may be given to a relaxation of the parking requirements in shopping areas for the change of use at ground floor level of premises from Use Class A1 (shops) to Use Class A2 (Financial & Professional Services).
4. Parking reserved for use by disabled persons: Refer to Appendix 1.
5. For cycle and motorcycle parking refer to Appendices 4 & 5.

c) SHOPS (including shops, supermarkets & superstores)**ZONE 1**

Type of Development	Operational	Non-operational
Shops (All sizes)	1 space per 400m ²	Nil

ZONES 2 & 3

Type of Development	Operational	Non-operational
Shops (< 200m ²)	1 commercial vehicle space	1 space per 60m ²
Shops and small supermarkets (201m ² –1000m ²)	2 commercial vehicle spaces	1 space per 40m ²
Shops and small supermarkets (1001m ² –2000m ²)	3 commercial vehicle spaces	1 space per 40m ²
Supermarkets & superstores (predominately food) (> 2000m ²)	3 commercial vehicle spaces	1 space per 14m ²

ZONES 4 & 5

Type of Development	Operational	Non-operational
Shops (< 200m ²)	1 commercial vehicle space	1 space per 60m ²
Shops and small supermarkets (201m ² –1000m ²)	2 commercial vehicle spaces	1 space per 20m ²
Shops and small supermarkets (1001m ² –2000m ²)	3 commercial vehicle spaces	1 space per 20m ²
Supermarkets & superstores (predominately food) (> 2000m ²)	3 commercial vehicle spaces	1 space per 14m ²

ZONE 6

Type of Development	Operational	Non-operational
Shops(All sizes)	1 commercial vehicle space	1 space per 60m ²

Notes relating to shops parking standards for all zones

1. The non-operational standard assumes a retail/non-retail ratio of 75/25. Variation may be applied at the discretion of the Local Authority when a different ratio is used.
2. Although 'retail parks' may have shared parking, such developments will still require similar levels of parking to single stores, because of the longer duration of parking.
3. Where existing premises are used for the establishment of a stall type market, the applicant shall identify a location for the provision of visitor parking.
4. For premises up to a maximum of 200m² gross floor space, an increase of 20% will be permitted without the need for additional parking. This allowance can only be made once, and any parking displaced must be relocated.
5. Evidence suggests that increases in transactions at supermarkets are not proportional to increases in floor area, e.g. extensions of 33% of gross floor area produce a 10% increase in transactions.
6. The non-operational standard includes employees parking.
7. Parking reserved for disabled people: refer to Appendix 1.
8. For cycle and motorcycle parking refer to Appendices 4 & 5.
9. In addition to the operational parking requirements for servicing purposes, sufficient additional space must always be provided to allow servicing vehicles to both enter and leave the curtilage of the store servicing area in a forward gear.

d) RETAIL WAREHOUSING AND GARAGES

ZONES 2 to 5

Type of Development	Operational	Non-operational
Retail Warehousing (non-food) (non-DIY) (> 1000m ²)	3 commercial vehicle spaces	1 space per 30m ²
Retail Warehousing (DIY & Garden Centres) (> 1000m ²)	3 commercial vehicle spaces	1 space per 20m ²
Builders Merchants (Trade & Retail)	3 commercial vehicle spaces	1 space per 80m ² & 10% of GFA
Cash & Carry Warehousing (Trade Only) (> 1000m ²)	3 commercial vehicle spaces	1 space per 50m ²
Open Air Markets & Car Boot Sales	1 space per stall pitch	1 space per 30m ² of gross stall pitch area including pedestrian circulation area
Garages	1 car/lorry space per each car/lorry service bay	2 car/lorry spaces per each service bay.
Service Stations (exhausts, MoT, tyres etc.)	1 lorry space & 20% of GFA	2 car/lorry spaces per each service bay.
Petrol Filling Stations (see note 12 re. associated convenience stores)	1 space for petrol tanker	4 spaces for ancilliary use (eg automatic car wash)
Car Sales Premises	1 space for car transporter	1 space per 50m ² of retail area (internal & external)
Motorcycle Sales Premises	1 commercial vehicle space	1 space per 50m ² of retail area (internal & external)
Driving Schools Private Hire / Vehicle Hire Licensed Taxis	1.25 spaces per vehicle operated	1 space per 3 auxiliary staff

Note:

It is assumed that developments of this nature will not be permitted within either Zone 1 or Zone 6. Consequently no data is provided for these Zones.

Notes relating to retail warehouses and garages parking standards for all zones

1. The range of trip generation and parking demand at retail warehouses varies to a considerable extent. The parking requirements of the most common types of store can be classified in broad bands. This is reflected by the tabulated requirements.

Highest requirement	-	DIY stores
Mid-range requirements	-	Electrical/gas appliance, flat pack furniture stores
Lowest requirement	-	Assembled furniture/carpet stores, household and leisure goods stores

2. Although 'retail parks' may have shared parking, such developments will still require similar levels of parking to single stores, because of the longer duration of parking.
3. Where existing premises are used for the establishment of a stall type market, the applicant shall identify a location for the provision of visitor parking.
4. For premises up to a maximum of 200m² gross floor space, an increase of 20% will be permitted without the need for additional parking. This allowance can only be made once, and any parking displaced must be relocated.
5. Evidence suggests that increases in transactions at retail and warehousing premises are not proportional to increases in floor area; e.g. extensions of 33% of sales floor area produce a 10% increase in transactions
6. The non-operational standard includes employees parking.
7. Relaxation may be given to the parking requirements at fast service centres, e.g. tyres, exhausts. MOT etc.
8. Where car sales premises include external display areas, additional parking space will be required.
9. Parking reserved for disabled people: refer to Appendix 1.
10. For cycle and motorcycle parking refer to Appendices 4 & 5.
11. In addition to the operational parking requirements for servicing purposes, sufficient additional space must always be provided to allow servicing vehicles to both enter and leave the curtilage of the premises' servicing area in a forward gear.
12. Convenience stores located at petrol filling stations will attract customers who do not also purchase petrol and will therefore require parking space. The additional requirement for this must be assessed as for a small shop.

e) INDUSTRY AND INDUSTRIAL WAREHOUSING**ZONE 1**

Type of Development	Operational	Non-operational
Small Industry (<1000 m ²)	1 van space	Nil
Industry	1 space per 1000 m ²	Nil
Highly Technical Industry	1 space per 1000 m ²	Nil
Industrial Warehouses	1 space per 1000 m ²	Nil
Storage Warehouses	1 space per 1000 m ²	Nil

ZONES 2 – 4

Type of Development	Operational	Non-operational
Small Industry (< 100m ²)	1 van space	1 space
Small Industry (< 235m ²)	1 van space	2 spaces
Industry	See Note 5	1 space per 120 m ²
Highly Technical Industry	See Note 5	1 space per 35 m ²
Industrial Warehouses	See Note 5	1 space per 140 m ²
Storage Warehouses	1 commercial space per 500 m ²	Nil
Distribution Centres (<1000 m ²)	35% of GFA	1 space per 120 m ²
Distribution Centres (>1000 m ²)	25% of GFA	1 space per 120 m ²

INDUSTRY AND INDUSTRIAL WAREHOUSING

ZONES 5 & 6

Type of Development	Operational	Non-operational
Small Industry (< 100m ²)	1 van space	1 space
Small Industry (< 235m ²)	1 van space	2 spaces
Industry	See Note 5	1 space per 80 m ²
Highly Technical Industry	See Note 5	1 space per 20 m ²
Industrial Warehouses	See Note 5	1 space per 140 m ²
Storage Warehouses	1 space per 500 m ²	Nil
Distribution Centres (<1000 m ²)	35% of GFA	1 space per 80 m ²
Distribution Centres (≥1000 m ²)	25% of GFA	1 space per 80 m ²

Notes relating to industry and industrial warehousing parking standards for all zones

- Vehicles should be able to enter and leave the site in forward gear.
- Relaxation permitted for operational space when special servicing arrangements are made.
- Visitor parking is included in non-operational parking.
- For premises up to a maximum of 235m² gross floor space, an increase of 20% will be permitted without the need for additional parking. This allowance can only be made once and any parking displaced must be relocated.
- Operational requirements:

GFA m ²	Minimum m ²	GFA m ²	Minimum m ²	GFA m ²	Minimum m ²
100	70	500	100	1,001	150
250	85	1,000	150	2,000	200

Above 2,000 m² GFA, the required minimum operational area should be taken as 10% of GFA.

- The General Development Order limit of 235m² is defined as the upper cut off for size for units to encourage new firms requiring garage size sites. Larger units are defined as, "Industry".
- Industries of a highly technical nature are companies specialising in technical innovation usually microprocessor based.
- If the premises are to be used as a distribution depot, adequate space must also be provided to accommodate commercial vehicles that are likely to be parked overnight.
- Parking reserved for Disabled People: See Appendix 1.
- For cycle and motorcycle parking refer to Appendices 4 & 5.

f) PLACES OF ENTERTAINMENT**ZONE 1**

Type of Development	Operational	Non-operational
All development types	1 commercial vehicle space	Nil

ZONES 2 - 4

Type of Development	Operational	Non-operational
Children's Play Centres	1 space per 3 members of staff	1 space per 20m ² of play area
Assembly Halls (Commercial) e.g. Bingo Hall	1 commercial vehicle space	1 space per 8 m ²
Assembly Halls (Social) e.g. Unlicensed Club Community Centre	1 commercial vehicle space	1 space per 10 m ²
Cinemas, Theatres & Conference Centres	1 commercial vehicle space	1 space per 5 seats
Stadia	1 commercial vehicle space	1 space per 15 seats

ZONES 5 & 6

Type of Development	Operational	Non-operational
Children's Play Centres	1 space per 2 members of staff	1 space per 15m ² of play area
Assembly Halls (Commercial) e.g. Bingo Hall	1 commercial vehicle space	1 space per 8 m ²
Assembly Halls (Social) e.g. Unlicensed Club Community Centre	1 commercial vehicle space	1 space per 10 m ²
Cinemas Theatres & Conference Centres	1 commercial vehicle space	1 space per 3 seats
Stadia	1 commercial vehicle space	1 space per 15 seats

Notes relating to places of entertainment parking standards for all zones

1. In addition to the operational parking requirements for servicing purposes, sufficient additional space must always be provided to allow servicing vehicles to both enter and leave the curtilage of the premises' servicing area in a forward gear.
2. Appropriate provision must be provided for use by disabled people.
3. For cycle and motorcycle parking refer to Appendices 4 & 5.

g) HOTELS AND RESTAURANTS**ZONE 1**

Type of Development	Operational	Non-operational
All development types	1 commercial vehicle space	Nil

ZONES 2 - 4

Type of Development	Operational	Non-operational
Hotels	1 commercial vehicle space	1 space per 3 non-resident staff & 1 space per bedroom
Public Houses & Licensed Clubs	1 commercial vehicle space	1 space per 3 non-resident staff & 1 space per 5 m ² of public area including servery
Restaurants	1 commercial vehicle space	1 space per 3 non-resident staff & 1 space per 7m ² of dining area
Cafes & Drive-Thru Restaurants (See Note 5)	1 commercial vehicle space	1 space per 3 non-resident staff & 1 space per 14m ² of dining area
Hot Food Takeaways	1 commercial vehicle space	1 space for non-resident staff & adequate on-street parking for customers nearby
Transport Cafes	1 commercial vehicle space	1 space per 3 non-resident staff & 1 commercial vehicle space per 2 seats

Notes relating to hotels and restaurants for all zones

1. Facilities for non-residents should be assessed by applying the appropriate category. An allowance should be applied where facilities are to be shared.
2. The range in the parking requirements between zones allows for the distinction between 'country' public houses and 'suburban' public houses which are likely to have a higher proportion of walk-in trade.
3. The parking requirement will be relaxed for public houses built before 1914 to permit redevelopment or extension up to a 20% increase in gross floor area without extra parking being required.
4. The non-operational requirement for restaurants and cafes in established shopping areas may be relaxed if it can be shown that they are 'incidental' to the shopping area or where such restaurants are used largely in the evening when adequate parking exists in the vicinity. However, adequate parking for staff must be provided at the rear. (This does not apply to transport cafes).

HOTELS AND RESTAURANTS

ZONES 5 & 6

Type of Development	Operational	Non-operational
Hotels	1 commercial vehicle space	1 space per 3 non-resident staff & 1 space per bedroom
Public Houses & Licensed Clubs	1 commercial vehicle space	1 space per 3 non-resident staff & 1 space per 3 m ² of public area including servery
Restaurants	1 commercial vehicle space	1 space per 3 non-resident staff & 1 space per 7m ² of dining area
Cafes & Drive-Thru Restaurants (See Note 5)	1 commercial vehicle space	1 space per 3 non-resident staff & 1 space per 14m ² of dining area
Hot Food Takeaways	1 commercial vehicle space	1 space for non-resident staff & adequate on-street parking for customers nearby
Transport Cafes	1 commercial vehicle space	1 space per 3 non-resident staff & 1 commercial vehicle space per 2 seats

Notes relating to hotels and restaurants for all zones (contd.)

5. Restaurants including drive through facilities for ordering and collecting food by car must have an internal segregated access for this purpose and be provided with a minimum of 6 waiting spaces.
6. In addition to the operational parking requirements for servicing purposes, sufficient additional space must always be provided to allow servicing vehicles to both enter and leave the curtilage of the premises' servicing area in a forward gear.
7. Appropriate provision must be provided for use by disabled people.
8. For cycle and motorcycle parking refer to Appendices 4 & 5.

h) COMMUNITY ESTABLISHMENTS

ZONE 1

Type of Development	Operational	Non-operational
Health Centres & Surgeries	1 space per practitioner	Nil
Churches & Places of Worship	1 commercial vehicle space	Nil
Chapels of Rest & Funeral Homes	3 commercial vehicle spaces	Nil
Public Leisure Centres	1 commercial vehicle space	Nil
Fitness Clubs, Leisure Clubs & Sports Clubs (See Note 6)	1 commercial vehicle space	Nil
Marinas	1 car and trailer space	Nil
Libraries	1 commercial vehicle space	Nil

ZONES 2 – 6

Type of Development	Operational	Non-operational
Hospitals (See Note 1)	Essential vehicles as required	2.5 spaces per bed
Health Centres & Surgeries	1 space per practitioner (See Note 2)	1 space per 3 ancillary staff (1 space per 2 in Zones 5 & 6) & 3 spaces per practitioner
Churches & Places of Worship	1 commercial vehicle space	1 space per 10 seats or 1 space per 8m ² of praying floorspace (See Note 3)
Chapels of Rest	3 commercial vehicle spaces	As per Churches etc.
Funeral Homes	3 commercial vehicle spaces	1 space per 2 members of staff
Public Leisure Centres	1 commercial vehicle space	1 space per 2 facility users & 1 space per 3 spectators
Fitness Clubs, Leisure Clubs & Sports Clubs (See Note 6)	1 commercial vehicle space	1 space per 2 facility users
Marinas	1 car and trailer space	1 space per berth
Libraries	1 commercial vehicle space	1 space per 45m ²

Notes relating to community establishments parking standards for all zones

1. This level of provision would be appropriate for acute and neighbourhood District Hospitals. For other types of hospitals a lower level of provision may be acceptable.
2. Practitioner to include doctor, dentist, nurse, health visitor etc.
3. This range is intended to reflect different catchment areas of churches and places of worship. One serving a local area would require a lower provision than one serving a wide area.
4. Consideration must be given to the provision of a coach parking area where appropriate and to cycle and motorcycle parking.
5. In addition to the operational parking requirements for servicing purposes, sufficient additional space must always be provided to allow servicing vehicles to both enter and leave the curtilage of the premises' servicing area, where provided, in a forward gear.
6. Clubhouse bar and restaurant facilities must always be separately assessed.
7. Parking reserved for disabled people: See Appendix 1.
8. For cycle and motorcycle parking refer to Appendices 4 & 5.

i) EDUCATIONAL ESTABLISHMENTS

ZONE 1

Type of Development	Operational	Non-operational
All Educational Establishments	1 commercial vehicle space	Nil

ZONES 2 - 4

Type of Development	Operational	Non-operational
Day Nurseries & Creches, (new build property)	1 commercial vehicle space	1 space per 2 full time staff
Day Nurseries & Creches, (converted property)	Included in non-operational requirement	1 space per 2 full time staff (See Note 3)
Nursery Infants Primary Schools	1 commercial vehicle space	1 space per each member of teaching staff, 1 space per 2 ancillary staff & 3 visitor spaces
Secondary Schools	1 commercial vehicle space	1 space per each member of teaching staff, 1 space per 2 ancillary staff, 1 space per 20 students of age 17 and 3 visitor spaces. Bus parking as required
Colleges of Higher/Further Education (See Note 6)	1 commercial vehicle space	1 space per each member of teaching staff, 1 space per 2 ancillary staff, 1 space per 8 students and 5 visitor spaces.

Notes relating to educational establishments

1. In addition to the non-operational parking an area must be provided for the picking up and setting down of school children.
2. In the case of Day Nurseries in converted properties the availability of adequate kerbside capacity (i.e. unrestricted parking) should be taken account of.
3. This should be assessed when the nursery is at full capacity. Where part-time staff are employed they should be aggregated to their full time equivalents.
4. Experience has shown that a minimum of 15 car spaces will be required for most other types of schools. Exceptions to this may be specialised (e.g. religious or Welsh) secondary schools with a large catchment area where a reduced number may be adequate, or larger schools in each category where a substantial increase (up to 50) may be desirable. With regard to buses, sufficient off street spaces should be provided for all services that the operator of the new school anticipates running for pupils, with the exception of passing service buses.

EDUCATIONAL ESTABLISHMENTS

ZONES 5 & 6

Type of Development	Operational	Non-operational
Day Nurseries & Creches, (new build property)	1 commercial vehicle space	1 space per 2 full time staff
Day Nurseries & Creches, (converted property)	Included in non-operational requirement	1 space per 2 full time staff
Nursery/Infants/Primary Schools	1 commercial vehicle space	1 space per each member of teaching staff, 1 space per 2 ancillary staff & 3 visitor spaces
Secondary Schools	1 commercial vehicle space	1 space per each member of teaching staff, 1 space per 2 ancillary staff, 1 space per 10 students of age 17, & 3 visitor spaces. Bus parking as required
Colleges of Higher/Further Education (See Note 6)	1 commercial vehicle space	1 space per each member of teaching staff, 1 space per 2 ancillary staff, 1 space per 5 students and 5 visitor spaces.

Notes relating to educational establishments (contd.)

5. The parking area should include a facility for vehicles to turn without reversing. In exceptional circumstances a circulation/turning area remote from pupil circulation areas would be acceptable.
6. Where there is a high level of part-time (day release) students, the standard for Colleges of Higher Education/Universities is increased to 1 per 3 students.
7. Where the school is used for dual social and adult educational purposes, the use of hard playground surfaces for parking is acceptable.
8. Definitions of schools for the purposes of these standards:-
 - Nursery - pre school age-groups 3-5 often in converted residential property.
 - Infants - formal schools ages 3 to 7
 - Primary - schools for children in the range 5 or 7 to 11
 - Secondary - age range 11 to 18

Colleges of Higher and Further Education - includes sixth form colleges.
9. Appropriate provision must be provided for use by disabled people
10. Appropriate provision must be provided for parental drop off/pick up of children as dictated by local circumstances and any school travel plan. Drop off areas must be located so that the safety of pupils walking or cycling to school is not jeopardised.
11. For cycle and motor cycle parking refer to Appendices 4 & 5.

Examples of the use of Parking Standards

- (a) Proposed new shop and office development in a rural small local centre (Zone 5)

Public transport accessibility is poor. The development comprises 500m² shopping (5 units) on the ground floor and 1000m² offices on the first and second floors. (Gross floor area including external walls).

The parking requirement is assessed as follows:-

SHOPPING USE -

Operational Parking = Space for 2 commercial vehicles

Non Operational Parking 1 space / 20m² = 25 spaces

OFFICE USE

Non Operational Parking 1 space / 25m² = 40 spaces

TOTAL PROVISION: Space for 2 Commercial Vehicles + 65 spaces

- (b) Change of use from industry to non-food retail warehouse (mixed) (in Zone 2)

Gross floor area 1500m² on an industrial estate.

The operational requirement for industrial premises of 1500m² is (from note 5) 175m² of yard space and 13 non-operational parking spaces (1 space / 120m²).

The requirement for retail warehousing is 3 commercial vehicle bays (225m²) and 50 spaces (1 space / 30m²).

Therefore, an additional operational area of 50m² should be provided so that a minimum of three commercial vehicles can be accommodated; plus an additional 37 parking spaces unless the site already has provision for 50 parked cars.

- (c) Conversion of a large 3-storey 5-bedroomed Victorian House to three one-bedroomed Flats (in Zone 3)

The parking requirement for the original house is three parking spaces, but given the age of the property, these may not actually be present.

The parking requirement for the flats is 1 space per bedroom. Three parking spaces are therefore required in theory. These should, if possible, be provided at the rear of the premises. If the site has no existing parking, the conversion will not require any although it would be desirable to gain these parking spaces. If the site is too small to accommodate three cars and the house fronts a local road that is not a bus route and kerbside parking pressure is not evident then an allowance of on-street parking immediately outside may be possible. Local circumstances should always dictate the approach to be taken.

APPENDICES

<i>Appendix 1</i>	<i>Disabled Parking</i>
<i>Appendix 2</i>	<i>Layout of parking Areas</i>
<i>Appendix 3</i>	<i>Cycle Parking Standards</i>
<i>Appendix 4</i>	<i>Motorcycle Parking Standards</i>
<i>Appendix 5</i>	<i>Sustainability</i>
<i>Appendix 6</i>	<i>Landscaping</i>

APPENDIX 1

ACCESS FOR DISABLED PERSONS

GUIDANCE NOTES FOR APPLICANTS

All new public buildings are now required, where reasonable and practicable, to be accessible to and have facilities for disabled people. The requirements of the Chronically Sick and Disabled Persons Act 1970 and the Chronically Sick, Disabled Persons (Amendment) Act 1976 and Disability Discrimination Act 2005 apply to a wide range of buildings, including: offices, shops, banks, post offices, sports centres, hotels, restaurants and public houses, theatres and cinemas, exhibition centres, libraries and museums, community and church halls; together with all places of education, including schools, universities and colleges. This list is not exhaustive and other types of building can fall within the terms of the Act.

In publishing a comprehensive document on parking standards, it is recognised that the fundamental requirement of access to buildings by disabled persons is very much bound up with the parking arrangements and therefore this Appendix has been prepared to draw the attention of developers to these complementary matters.

It is recommended that the following publications be used as the basis for guidance:

“Reducing Mobility Handicaps”

Guidelines published by The Institution of Highways and Transportation, 6 Endsleigh Street, London, WC1H 0DZ.

“Planning and Access for Disabled People”

A good practice guide published by the Department for Communities and Local Government, PO Box 236, Wetherby, LS23 7NB

The former document is particularly detailed on the external considerations of a development whilst the latter concentrates more strongly upon the Planning System, however, they should be read and applied in a complementary manner.

In addition to these two documents, developers must give due consideration to the following aspects:

- A. The signing of pedestrian routes - having established the most convenient location for parking the vehicles of disabled persons, it is essential that a clear system of sign posting to the appropriate access catering for disabled persons should be devised and, implemented by the developer.
- B. The gradient of any ramp should be as slight as possible. The use of the term 'maximum gradient 1 in 12' should not be construed as being acceptable to disabled persons, except where it is absolutely unavoidable. Developers should consider very carefully the relative levels of parking spaces and finished floor levels at an early stage in their planning, so that a level or near level pathway (preferably less than 5% gradient) can be maintained between the two, if at all possible.
- C. The difficulty caused to disabled persons in gaining entrance into a building is covered by the documents but the delay in opening doors etc., can cause considerable discomfort and therefore the developer should consider providing a canopy over entrances designed for the use of disabled persons.

PARKING RESERVED FOR DISABLED PEOPLE

It is recommended that appropriately positioned parking places, preferably within 50 metres of the facility served by the car park and which are adequate in size and number, shall be provided for people with disabilities. The size of each parking place and level of provision should be in accord with the recommendations in the Department for Transport's document 'Inclusive Mobility', 'A Guide to Best Practice on Access to Pedestrian and Transport Infrastructure' (2002).

The recommended proportions of spaces for Blue Badge holders are:-

- For car parks associated with existing employment premises;
2% of the total car park capacity, with a minimum of one space.
- For car parks associated with new employment premises;
5% of the total car park capacity.
- For car parks associated with shopping areas, leisure or recreational facilities and places open to the general public;
A minimum of one space for each employee who is a disabled motorist plus 6% of the total car park capacity for visiting disabled motorists.
- For car parks associated with railway stations;
A minimum of one space for each railway employee who is a disabled motorist plus:
for a car park with fewer than 20 spaces, one disabled space
for a car park of 20 to 60 spaces, two disabled spaces
for a car park of 61 to 200 spaces, three disabled spaces
for a car park with more than 200 spaces, 4% of capacity plus four disabled spaces.

Disabled persons parking bays in off-street locations should be marked out with yellow lines and a yellow wheelchair symbol within the parking space. A sign, or if appropriate signs should be provided at the entrance to the car park to direct disabled motorists to designated parking spaces which, if the car park is not under cover, should also have raised signs at the head of the reserved bays. Signs inside the car park should show the most convenient way to the facilities served by the car park, with an approximate distance to those facilities. The marking out should comply with British Standard BS8300:2001 'Design of buildings and their approaches to meet the needs of disabled people – Code of Practice' as well as to the recommendations of the Department for Transport's document 'Inclusive Mobility', 'A Guide to Best Practice on Access to Pedestrian and Transport Infrastructure' (2002).

On street disabled parking bays should be indicated by signs and marked out in full compliance with the Traffic Signs Regulations and General Directions (1994). Each bay should have a raised sign at the head of the bay to ensure that if snow or fallen leaves obscure the road markings, the purpose of the bay is still apparent.

APPENDIX 2

LAYOUT OF PARKING AREAS

Cars: The standard dimensions of car parking spaces are: 4.8m x 2.6m

In ground parking areas the average requirement per car including space for access is 21m² (226 sq. ft. approx)

ALTERNATIVE WAYS OF ARRANGING 12 SPACES

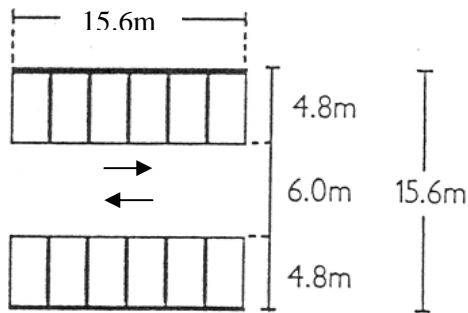

90° PARKING

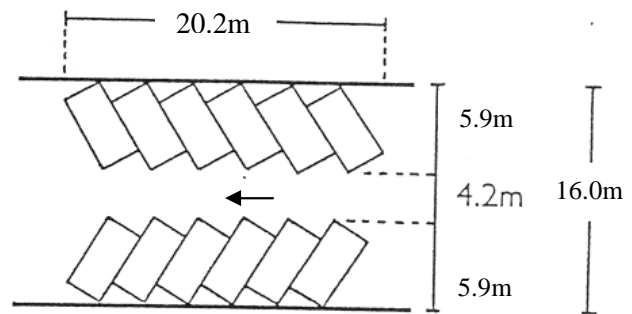

60° PARKING

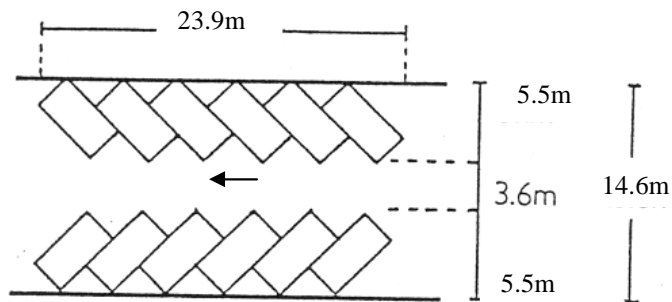

45° PARKING

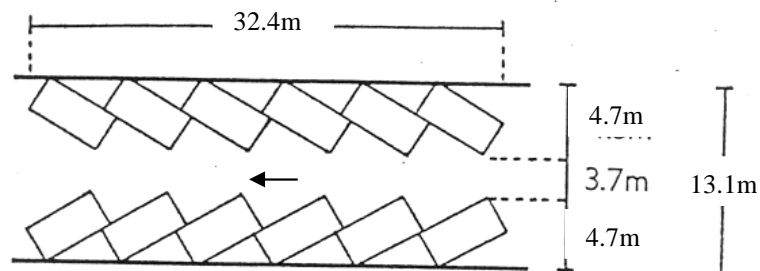

30° PARKING

Disabled Driver's Vehicles - The standard dimensions of car parking spaces are: 4.8m x 3.6m

This allows transfer from vehicle to wheelchair. With certain layouts 4.8m x 2.6m bays can be used but additional provision must be made for the disabled to transfer to wheelchairs (see below)

Access to the rear must be provided.

Alternative ways of arranging disabled spaces

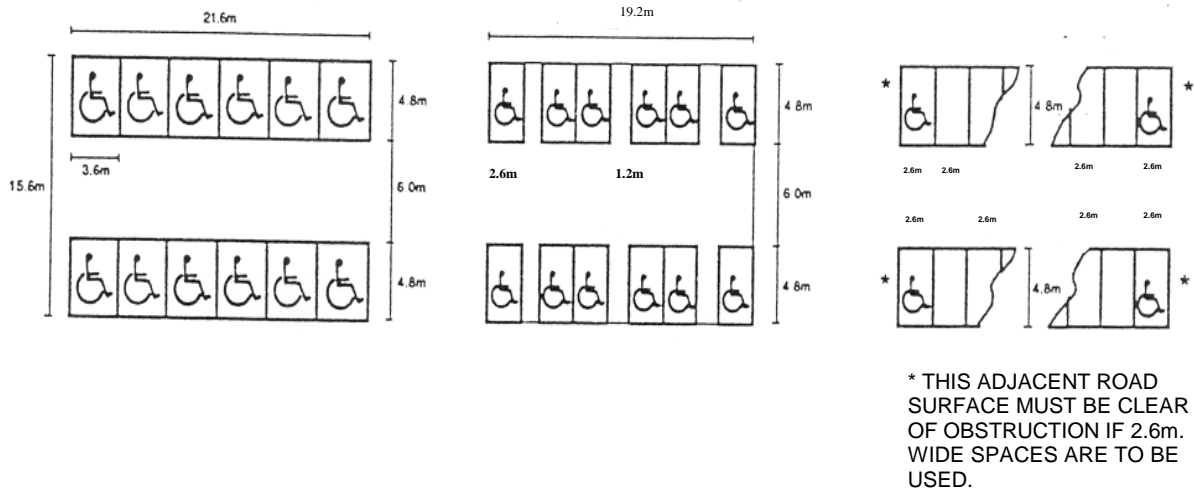

Vehicle Bays - The bay must be of sufficient size and be located so that the vehicle can be manoeuvred within the site, e.g. the 12m rigid lorry requires a absolute minimum of 105m² to allow it to leave a site in forward gear. Further details of good design practice can be found in appropriate Highway Authority Design Standards or 'Designing for Deliveries', Freight Transport Association 1998.

Articulated Vehicles	16.5m x 2.55m
Articulated Low loader Vehicles	18.0m x 2.55m
Rigid Vehicles	12.0m x 2.55m
Buses and Coaches (two axle)	13.5m x 2.55m
Buses and Coaches (three axle)	15.0m x 2.55m
Buses and Coaches (Articulated)	18.75m x 2.55m

Refrigerated vehicles maximum allowed width is 2.65m

All vehicles should enter and leave the site in forward gear.

Further guidance on parking layouts can be found in Manual for Streets.

APPENDIX 3

CYCLE PARKING STANDARDS

1. Short stay parking and long stay parking are separately considered in the following tables. Short stay parking addresses the needs of customers or other visitors to a development, whereas long stay parking is applicable to the needs of staff. Staff should also be encouraged to cycle to work by the provision of additional facilities such as lockers, changing areas and showers. Covered cycle parking stands can also be an important element in encouraging the use of cycles.
2. Cycle parking should be located in a safe, secure and convenient location. Care should also be taken to ensure that cycle parking facilities are not located where they may obstruct pedestrians, disabled persons and particularly people with sight problems.
3. Appropriate signing should always be provided to indicate the location of short term cycle parking.
4. For reasons of security, cycle parking facilities should be located in areas that are visible and therefore allow for informal surveillance. In certain instances this could need to be supplemented through the introduction of CCTV or other security means.
5. Guidance on the design of cycle parking is available in the DfT Traffic Advisory Leaflet 5/02 "Key Elements of Cycle Parking" and in Sustrans Information Sheet FF37 "Cycle Parking".
6. All residential developments must be accessible by cycles and cycle storage must be a factor of dwelling design. In appropriate circumstances, convenient communal facilities may be provided. Guidance on this subject is available within Manual for Streets.
7. Where a development is located within a commercial centre and it is not appropriate for a particular reason to provide cycle parking facilities, the developer should be asked to provide a financial contribution towards the provision of sustainable transport.
8. The provision of facilities for cyclists should be specifically considered whenever a Travel Plan is accepted.

TYPE OF DEVELOPMENT	CYCLE PARKING PROVISION	
	Long Stay	Short Stay
<u>a) Residential</u>		
Apartments	1 stand per 5 bedrooms	No requirement
Purpose built student accommodation	1 stand per 2 bedrooms	No requirement
Self contained elderly persons accommodation	1 stand per 20 bed spaces	1 stand per 20 bed spaces
<u>b) Offices</u>		
Offices	1 stand per 200m ²	1 stand per 1000m ²
Call Centres	1 stand per 150m ²	1 stand per 1000m ²
<u>c) Shops</u>		
Shops < 200m ²	1 stand per 100m ²	1 stand per 100m ²
Shops 201m ² – 1,000m ² : Food Non-food	1 stand per 500m ² 1 stand per 500m ²	1 stand per 500m ² 1 stand per 750m ²
Supermarkets	1 stand per 500m ²	1 stand per 500m ²

TYPE OF DEVELOPMENT	CYCLE PARKING PROVISION	
	Long Stay	Short Stay
<u>d) Retail Warehousing</u>		
Retail Warehousing: Non-food	1 stand per 500m ²	1 stand per 1000m ²
Cash & Carry Warehousing	1 stand per 500m ²	No requirement
Open Air Markets	1 stand per 500m ²	1 stand per 500m ²
Garages	1 stand per 250m ²	No requirement
Car Sales Premises	1 stand per 1000m ²	No requirement
<u>e) Industry and Industrial Warehousing</u>		
Industry	1 stand per 500m ²	1 stand per 1000m ²
Industrial Warehouses & Storage Centres	1 stand per 500m ²	No requirement
<u>f) Places of Entertainment</u>		
Assembly Halls: Commercial Social	1 stand per 10 staff Incl. in short term	1 stand per 40 seats 1 stand per 30 m ²
Cinemas, Theatres & Conference Centres	1 space per 10 staff	1 stand per 30 seats
Stadia	1 space per 10 staff	1 stand per 100 seats
<u>g) Hotels and Restaurants</u>		
Hotels & Public Houses	1 stand per 5 bedrooms	1 stand per 40m ² of public floor space
Restaurants & Cafes (All types)	1 stand per 10 staff	No requirement
<u>h) Community Establishments</u>		
Hospitals	1 stand per 20 beds	1 stand per 20 beds
Health Centres & Surgeries	Incl. in short term	1 stand per consulting room
Churches & Places of Worship	Incl. in short term	1 stand per 50m ² of public floor space
Public Leisure Centres	1 stand per 10 staff	1 stand per 50m ² of public floor space
Fitness Clubs	1 stand per 10 staff	1 stand per 25m ² of public floor space
Leisure Clubs & Sports Clubs	1 stand per 10 staff	1 stand per 10 facility users
Libraries	1 stand per 10 staff	1 stand per 30m ² of public floor space
<u>i) Educational Establishments</u>		
Day Nurseries & Creches	Incl. in short term	1 stand /30 children
Nursery, Infants & Primary Schools	1 stand per 5 staff and 1 stand per 20 children	1 stand /100 children
Secondary Schools & Colleges of Further Education	1 stand per 5 staff and 1 stand per 6 students of age 17	1 stand per 100 students
<u>j) Transport Facilities</u>		
Park & Ride and Car Parks	1 secure stand per 20 car park spaces	No requirement

APPENDIX 4

MOTORCYCLE PARKING STANDARDS

1. Motorcycle parking should be located in a safe, secure and convenient location where other vehicles cannot encroach or obstruct the motorcycle parking area.
2. Motorcycles are prone to theft. For reasons of security, motorcycle parking facilities should be located in areas that are visible and therefore allow for informal surveillance. Surrounding high walls or shrubbery should be avoided as they could provide cover for thieves. In certain instances the introduction of CCTV or other security means could be necessary. In particular these facilities should be located where other larger vehicles, such as vans, could not be used to steal the motorcycles.
3. Robust anchor points must be provided to lock the motor cycles to, but the design of the anchor points must be such that they are able to accommodate a wide range of motorcycle wheel sizes, but without affording easy leverage for bolt croppers or other equipment used for the purposes of theft. Care must also be taken to ensure that locking facilities do not present a trip hazard to pedestrians, disabled persons and particularly people with sight problems.
4. Covered motorcycle parking would clearly be of benefit to riders, particularly for long term parking, as would the supply of convenient litter bins as riders have little space for carrying surplus articles. It is also important to consider the supply of lockers for storage of riders protective clothing and helmets.
5. Motorcycle length and width dimensions are generally reduced when parked, as the front wheel will be turned to a locked position. The effective length and width vary between about 1600mm to 2300mm (length) and 650mm to 900mm (width). A bay size of 2.8m x 1.3m is recommended.
6. A further consideration is that of disabled riders. It is suggested that provision be made for disabled riders by way of special marked-out bays of increased size. Any rider experiencing reduced mobility and strength will benefit from extra room to position themselves to the side of their bike when manoeuvring or mounting. As the rider population ages, stiffness and reduced range of movement will make this a common issue.
7. Motorcycle parking bays should not be surfaced with bitumen based material as it can soften in hot weather, causing the stand of the motorcycle to sink and the bike to topple. Concrete surfaces should avoid this problem.
8. Further guidance is available in Manual for Streets.

TYPE OF DEVELOPMENT	MOTORCYCLE PARKING PROVISION
All classes of development	5% of provision for car parking

APPENDIX 5

SUSTAINABILITY

Other than for Zone 1 City Centre locations and Zone 2 Town Centre locations, the reductions in parking requirement for residential units shall not result in less than one parking space remaining (unless exceptional circumstances apply) and for all other developments the reduction shall not be applied unless an acceptable travel plan is also submitted. .

1. Sustainability points will be awarded to developments that are regarded as destination developments (other than residential developments in Zone 1, of which there are none within bridgend County Borough, or Zone 2 which is regarded as Town Centre) i.e. employment/commercial/leisure/educational facilities that meet the criteria below for their proximity, in terms of walking distance to local facilities, public transport, cycle routes and the frequency of local public transport. Award of these sustainability points will result in a reduction in parking requirement as detailed below:

Sustainability Criteria	Maximum Walking Distance	Single Sustainability Points
<p><u>Local Facilities</u></p> <p>Local facilities include a foodstore, post office, health facility, school etc. Access to two of these within the same walking distance will score single points, whereas access to more than two of these will double the points score.</p>	200m 400m 800m	3 pts 2 pts 1 pt
<p><u>Public Transport</u></p> <p>Access to bus stop or railway station</p>	300m 400m 800m	3 pts 2 pts 1 pt
<p><u>Cycle Route</u></p>	200m	1 pt
	Frequency	
<p><u>Frequency of Public Transport</u></p> <p>Bus or rail service within 800m walking distance which operates consistently between 7am and 7 pm. Deduct one point for service which does not extend to these times.</p>	5 minutes 20 minutes 30 minutes	3 pts 2 pts 1 pt

2. Travel Plans (Applies to Places of destination only)

Developers will be expected to provide effective measures to encourage employees/customers to reduce private car travel e.g. car sharing, car pools, company bus, cycle facilities including changing/shower facilities, financial incentives, public transport subsidies, appointment of travel plan coordinator, bonded travel plan agreement. Each defined measure will accrue half a sustainability point up to a maximum of 3 points.

3. Residential developments are regarded as vehicle points of origin i.e. where vehicles are stored overnight and whilst residents are encouraged to reduce unnecessary private car journeys there is no central government policy to reduce car ownership levels in view of the impact such a policy would have on the national economy. As stated in the strategic framework of this document an under provision of parking space at the point of origin will simply lead to congestion of the surrounding streets rather than a reduction in car ownership levels. Consequently the primary aim of this document is to reduce the availability of parking at the point of destination as it is this that will dissuade motorists from making unnecessary journeys. Consideration will also need to be given to securing private funding through developer contributions for parking restriction enforcement to ensure that employees do not simply park in nearby residential streets. With residential parking, a fundamental difference between these standards and their predecessors is the consideration of

the availability of unallocated parking areas which, where appropriate and safe, may be included in the parking provision for a residential dwelling (eg a 4 bedroom dwelling with space within its curtilage for 2 spaces may be acceptable if there is adequate space on the highway, provided kerbside space is not already at a premium, thereby satisfying a requirement for 3 spaces by providing 2 allocated, curtilage spaces and 1 unallocated kerbside space)

In terms of sustainability deductions for residential developments any reductions in overall parking space associated with residential development are limited to those areas of Bridgend that are identified as Zone 2 i.e. town centres. Sustainability points will be awarded to residential developments in Zone 2 that are able to make use of public car parks or in safe on street areas, if they have convenient access to local facilities and public transport facilities as set out in the table above.

The sustainability points score for a dwelling within 400m of a school and a post office (1 X 2pts = 2pts), within 300m of a bus stop (3pts) and having a service frequency of every 15 minutes but only between 8am and 6 pm (2 pts – 1pt = 1 pt) would score a total of 6 pts. It should be noted however that no discounts will be awarded for the submission of Travel Plans in relation to residential developments as these can only apply to places of destination.

Reductions in Parking Requirement

Sustainability Points	Parking Reduction (Per dwelling)	Sustainability Points	Parking Reduction
<u>Residential Developments</u>		<u>All Other Developments</u> (other than shops and retail warehouses)	
10 pts	2 spaces	10 pts	30%
7 pts	1 space	7 pts	20%
		5 pts	10%

APPENDIX 6

LANDSCAPING

Planting should be used in car parks to relieve the monotony of areas of paving: to define or screen parking bays, and to provide visual features. Landscaping is seen as an integrated part of the design of parking areas and not as an after thought. Grass, ground cover plants, shrubs and trees used in car parks should be pollution resistant varieties, and in the case of trees should not be a type liable to heavy leaf fall, fruit dropping or branch shedding. Particularly to be avoided are most varieties of lime, maiden hair and horse chestnut. Care should be taken that planting does not obscure sight lines at junctions or remove any degree of natural surveillance.

Plant selection should reflect local character and vegetation and draw on native as well as the more ornamental of exotic species. Ultimate height and spread should be considered in relation to nearby structures. Plant selection must exclude those species of plant that harbour litter.

A useful guide for species choice is available on a web site compiled by the Horticultural Trades Association in consultation with the Landscape Institute at www.plantspec.org.uk.

In some circumstances, hard landscaping may be more appropriate, e.g. concrete blocks, bricks, paving slabs, cobbles. The developer should make every effort to ensure that surface water from any permanent surface drains onto adjacent porous surfaces, thereby reducing the demand on the drainage system. Alternatively, the developer may wish to explore the use of permeable materials. However, compacted chippings would not be considered acceptable as they are likely to be dragged onto the highway to the detriment of highway and pedestrian safety. Therefore, impermeable surfacing such as concrete or tarmacadam extending across the full width of the replacement space should not be considered as a first option.

There is a wide variety of surfacing materials available, which can be used for car parks. The choice of which one to use in a specific situation will depend on the intensity of use expected, the desired appearance and the amount of money available for laying and maintenance.

The design and landscaping of car parks should take into account the guidance contained within the assessment guidelines of the Park Mark safer parking initiative of the Association of Chief Police Officers as well as the more general requirements of Planning Policy Wales Technical Advice Note 12: Design (TAN12).

BIBLIOGRAPHY

- DfT white paper, *A New Deal For Transport: Better For Everyone*, 1998, London, TSO
- Chronically Sick and Disabled Persons Act 1970*, London, TSO
- Chronically Sick, Disabled Persons (Amendment) Act 1976*, London, TSO
- Sustrans Information Sheet FF37, *Cycle Parking*, 2004, Bristol, Sustrans
- BSI, *Design of Buildings and their Approaches to Meet the Needs of Disabled People (BS 8300:2001)*, 2001, London, British Standards Institution
- Designing for Deliveries*, 1998, Tunbridge Wells, Freight Transport Association
- Disability Discrimination Act 2005*, London, TSO
- DETR advice note, *Encouraging Walking*, 2000, London, TSO
- Environment Act 1995*, London, TSO
- IHT Guidelines for *Providing for Journeys on Foot*, 2000, London, Institution of Highways and Transportation
- DfT, *Inclusive Mobility, A Guide to Best Practice on Access to Pedestrian and Transport Infrastructure*, 2002, London, TSO
- DfT Traffic Advisory Leaflet 5/02, *Key Elements of Cycle Parking*, 2002, London, DfT
- DfT, *Making Residential Travel Plans Work*, 2007, Wetherby, DfT
- DfT, *Making Residential Travel Plans Work: Good Practice Guidelines for New Development*, 2005, London, DfT
- DfT, *Manual for Streets*, 2007, London, Thomas Telford Publishing
- DfT, *Using the Planning Process to Secure Travel Plans*, 2002, London, DfT
- Standing Conference on Regional Policy in South Wales, *Parking Guidelines (Revised Edition 1993)*, 1993, Cardiff, South Glamorgan County Council
- Parking Strategies and Management*, 2005, London, Institution of Highways and Transportation
- ACPO, *Park Mark Safer Parking Assessment Guidelines*, 2007, Haywards Heath, British Parking Association
- DCLG, *Planning and Access for Disabled People: a good practice guide*, 2003, Wetherby, Communities and Local Government Publications
- DoE & DfT, *Planning Policy Guidance 13: A Guide to Better Practice*, 1994, London, TSO
- WAG, *Planning Policy Wales*, 2002, Cardiff, NAFW
- WAG, *Planning Policy Wales Technical Advice Note 12: Design*, 2002, Cardiff, NAFW
- WAG, *Planning Policy Wales Technical Advice Note 18: Transport*, 2007, Cardiff, NAFW
- IHT Guidelines for *Reducing Mobility Handicaps*, 1991, London, Institution of Highways and Transportation
- DCLG, *Residential Car Parking Research*, 2007, Wetherby, Communities & Local Government Publications
- Road Traffic Reduction Act 1997*, 1997, London, TSO
- Road Traffic Reduction Act 1998*, 1998, London, TSO
- Traffic Signs Regulations and General Directions 1994*, London, TSO
- Welsh Office, *Transporting Wales into the Future*, 1998, Cardiff, Welsh Office